



TECHNICAL DATA

GENERAL SPECIFICATIONS

Frequency response	130 - 15kHz
Sensitivity	92 ±3dB
Power handling	20W
Power taps	5W / 10W / 20W
Line input	100V
Mounting	pendant hung
Dimensions (diameter)	Ø254mm

PHYSICAL SPECIFICATIONS

Material	ABS
Component	8"
Finished colour	white RAL 9016
Net weight	2,2kg
Gross weight	3,1kg / 1pc
Packing dimension	330 x 330 x 310mm

SPEAKER SPECIFICATIONS

Voice coil size	KSV 20,4 x 0,14 x 2T
DC impedance	7,2 Ohm
Former	KAPTON
Magnet	Ferrite (305g) Ø80 x 32 x 15(Y30)
Basket	iron
Cone material	paper
Spider	cloth
Dust cap	paper cup
Net weight	640g

GB 820T

ABS SPHERICAL SPEAKER



OVERALL DIMENSIONS

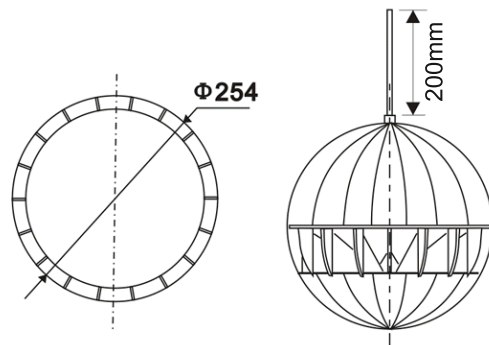

FREQUENCY RESPONSE

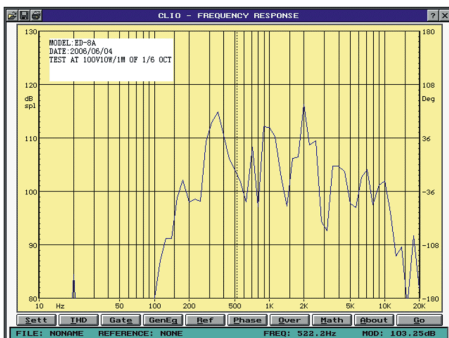
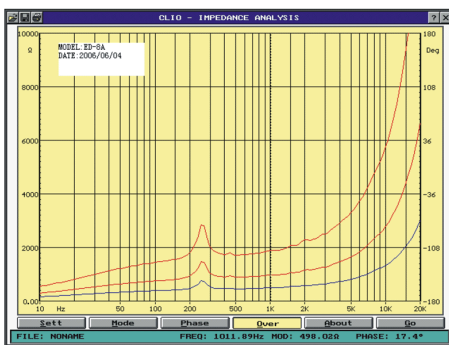

POLAR DIAGRAM

